

What Makes Boomerangs Come Back?



Ernie Esser

UC Irvine

Parts of a Boomerang

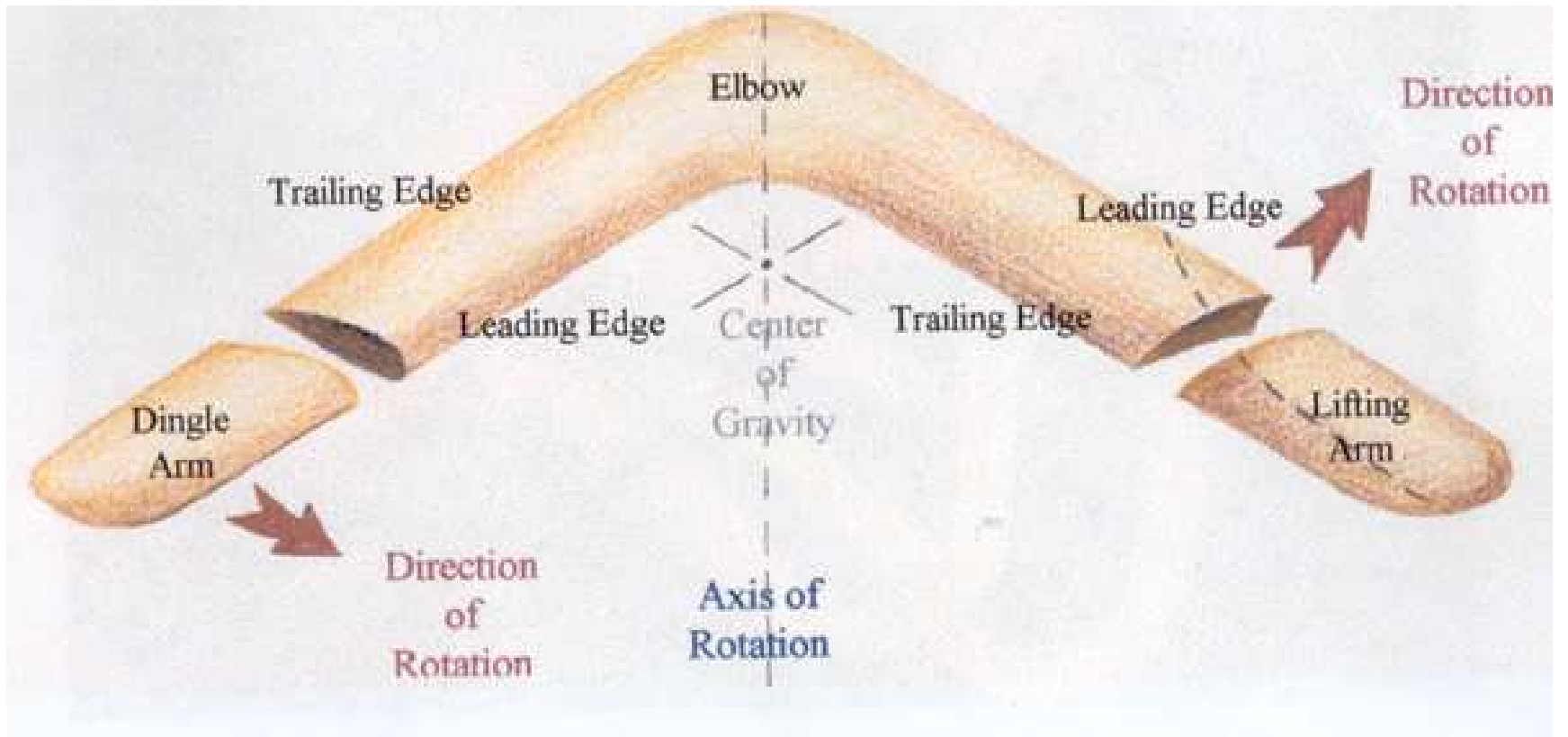

[Hawes, *All About Boomerangs*]

Right-Handed vs Left-Handed

Right



Left



There is a difference between the two. They are in fact mirror images of each other.

This presentation is geared towards right-handed boomerangs, which turn counter-clockwise when thrown. Left-handed boomerangs, on the other hand, turn clockwise.

Goals for the talk:

- Discuss the lift equation, why a boomerang generates lift and how these lift forces produce torque on a boomerang
- Explain gyroscopic precession and why torque on a boomerang makes it turn
- Estimate the characteristic radius of a boomerang's flight path
- Explain a boomerang's tendency to lay over as it flies
- Comment on how to construct a boomerang
- Discuss boomerang throwing and catching techniques

Aerodynamic Lift

An airfoil produces lift when the combined effects of its orientation (angle of attack) and its shape cause oncoming air to be deflected downward.

Sketch of Streamlines

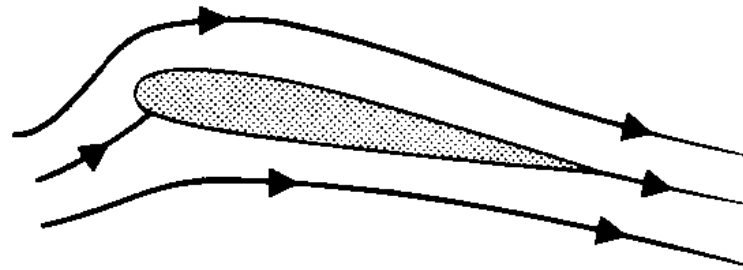

[Acheson, *Elementary Fluid Dynamics*]

Boomerang wing cross section

Leading Edge

Trailing Edge



Bevel on lifting arm

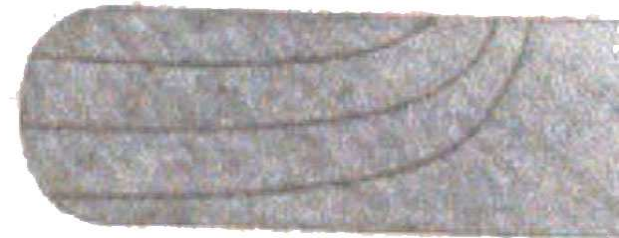

The Lift Equation

Under some simplifying assumptions, the lift produced by a wing is proportional to the area of the wing, the speed of the wing squared and the density of air. We will use the following approximation of lift force on a wing:

$$F_{Lift} = \frac{1}{2}\rho U^2 C_L A$$

ρ = density

U = speed

A = area

C_L = lift coefficient

Remark: This model puts the complex dependencies that are hard to compute, like the dependence of lift on boomerang shape, angle of attack, air viscosity, etc., into a single constant C_L .

Why is $F_{Lift} \propto \rho U^2$?

Intuition from Oversimplification

Downwash from a helicopter



Recall Newton's Second Law: force = rate of change of momentum

where momentum = mass · velocity

mass of air deflected per unit time $\propto \rho U$

change in deflected air's vertical velocity $\propto U$

$$\Rightarrow F_{Lift} \propto \rho U^2$$

A more local viewpoint

Consider air following the top curve of the airfoil in two dimensions

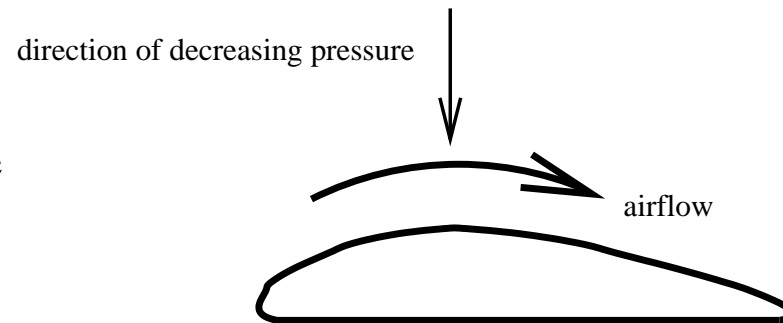

A downward force is required to accelerate the air this way.
(think centripetal force $\frac{mv^2}{r}$ for a spinning mass on a string)

This force comes from a difference in pressure, which is decreasing in the direction of the force.

Consequences:

- Expect lower than normal pressure near top of airfoil
- Expect tangential acceleration of oncoming air along top of airfoil

Bernoulli's Equation

Pressure P and velocity u are related by Bernoulli's equation

$$P + \frac{1}{2}\rho|\mathbf{u}|^2 = c \quad (\text{for some constant } c)$$

Assuming:

- constant density ρ
- zero viscosity μ (inviscid)
- incompressible
- steady flow (time independent)
- irrotational (no vortices)

Comment: If the flow is rotational, the equation still holds but c can be different on different streamlines.

To compute force on the airfoil, we can integrate P times the inward pointing normal \mathbf{n} along the boundary of the airfoil. Assuming $\mathbf{u} \rightarrow \alpha\mathbf{u}$ when $U \rightarrow \alpha U$, we again expect to have $F_{Lift} \propto \rho U^2$.

Another Viewpoint: Circulation

Under the previous assumptions, the solution to the equations for conservation of momentum and mass in the domain surrounding the airfoil is not unique.

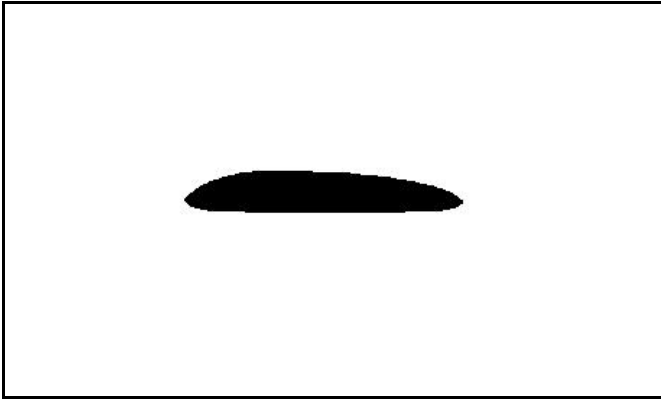

It is, however, determined by a quantity called circulation, Γ , that measures the counterclockwise rotation of air about the airfoil.

$$\Gamma = \int_C \mathbf{u} \cdot d\mathbf{s}$$

Γ is computed by adding up the tangential component of velocity \mathbf{u} along the boundary of the airfoil given by the curve C .

Viscous Effects Determine Circulation

For an airfoil with a corner at the trailing edge, all solutions to the inviscid problem have a singularity in the velocity there except for one. Adding even the tiniest amount of viscosity picks out the solution where a stagnation point is at the corner. (Kutta Condition)

Zero Circulation

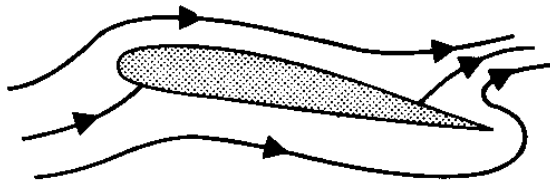

Negative Circulation

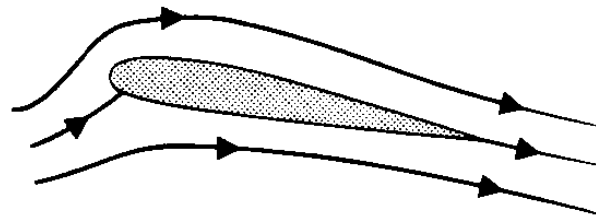

[Acheson, *Elementary Fluid Dynamics*]

Comments:

- Equal transit time argument is false. Negative circulation implies air moving even faster above airfoil.
- Need to include effect of viscosity to correctly model dynamics. Conservation of angular momentum plus decreasing circulation requires shedding of counterclockwise vortex.

Computing Lift and Drag

Assume uniform air speed U at infinity.

F_{Drag} is the force on the airfoil in the direction of the oncoming air, and

F_{Lift} is perpendicular to the flow.

$$F_{Lift} = -\rho U \Gamma$$

$$F_{Drag} = 0$$

- Good approximation of lift on an airfoil when viscosity and angle of attack are small
- Useless for computing drag because inviscid model doesn't have any tangential forces on airfoil

Note: To incorporate tangential shear forces due to viscosity,

$$F = \int_C (P - 2\mu D) \cdot \mathbf{n} ds$$

where D is the deformation matrix and depends on rates of change of velocity \mathbf{u} .

Getting Back to Lift Equation

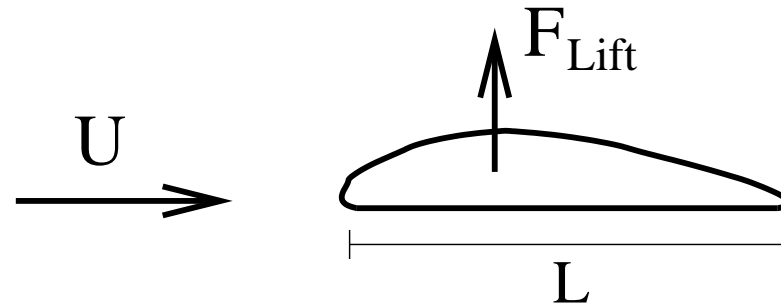

$$\Gamma \propto UL \quad \text{and} \quad F_{Lift} = -\rho U \Gamma$$

$$\Rightarrow F_{Lift} \propto \rho U^2 L$$

So for a wing with uniform crosssection we get back the lift equation:

$$F_{Lift} = \frac{1}{2} \rho U^2 C_L A$$

Note: If we measure or simulate F_{Lift} we can compute C_L .

Reynolds Number

General characteristics of the flow can often be determined from the unitless Reynolds number Re defined by

$$Re = \frac{\rho LU}{\mu} .$$

Where ρ = density
 L = characteristic length scale
 U = typical flow velocity
 μ = dynamic viscosity

- Small $Re \Rightarrow$ smooth, steady flow
- Large $Re \Rightarrow$ turbulent, unsteady flow, and thin boundary layer
- Inviscid approximation can work when Re is large

Re for boomerang is between 10^4 and 10^5

Re for cruising jumbo jet wing is on the order of 10^7

2D Navier Stokes Simulation

The Navier Stokes equations for an incompressible fluid with constant density ρ , constant viscosity μ , and no forcing terms are

$$\rho \frac{\partial \mathbf{u}}{\partial t} + \rho(\mathbf{u} \cdot \nabla) \mathbf{u} = -\nabla P + \mu \Delta \mathbf{u}$$

$$\nabla \cdot \mathbf{u} = 0$$

Simulate flow around 2D cross section of boomerang arm using semi-Lagrangian finite element method.

Boundary Conditions: Parabolic inflow on left side
 Neumann boundary condition on right side
 Zero velocity (no slip) on top, bottom and airfoil surface

Initial Condition: Zero velocity

Note: Displayed results will be for a zoomed in region surrounding the airfoil

Triangularization of Domain

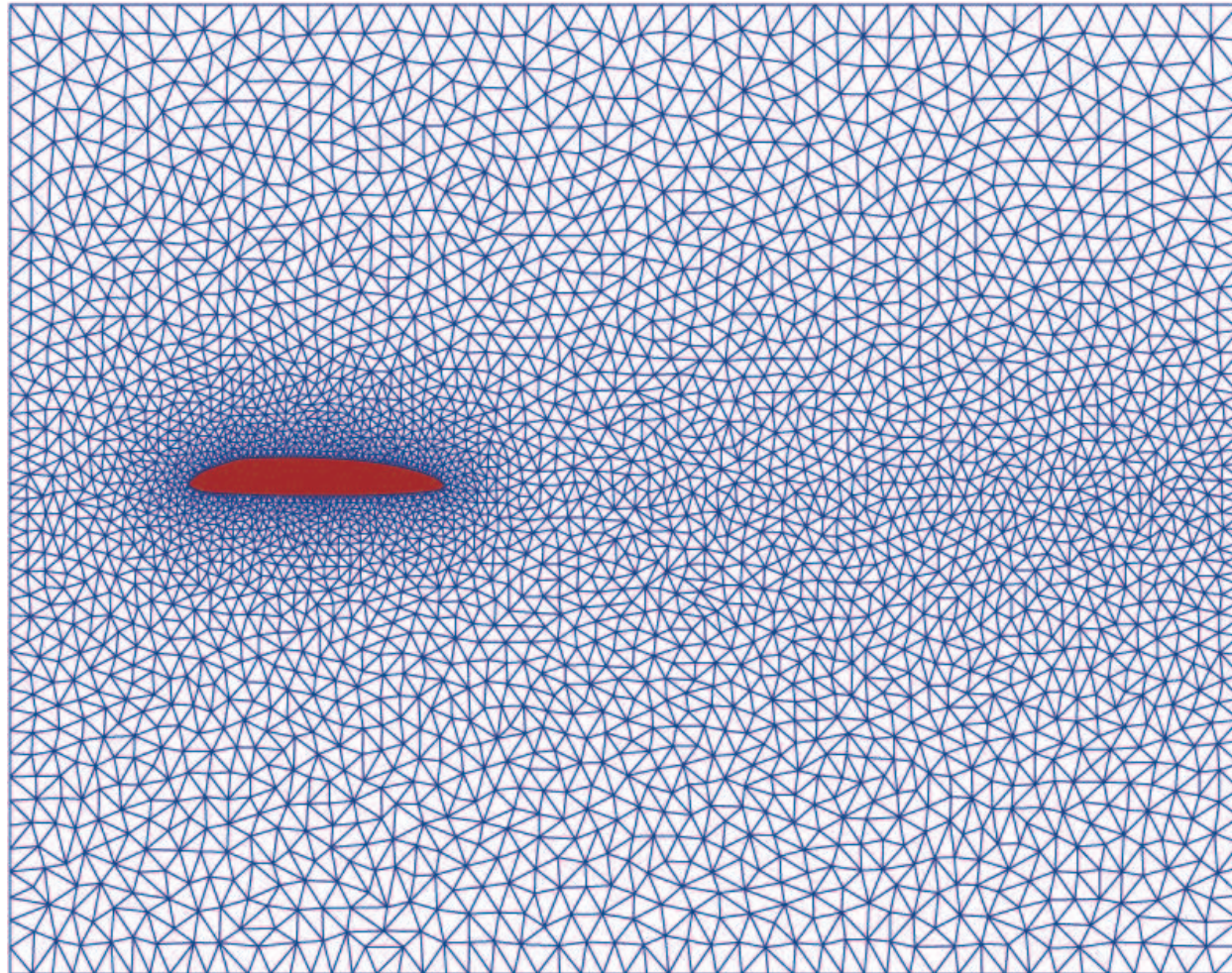

[Used distmesh software by Persson and Strang from <http://www-math.mit.edu/~persson/mesh/>]

Simulation of P for $\max U_{in} = 10$

Pressure P from $t = 0$ to $t = .04$, F_{Lift} and F_{Drag}

Re = 27000 , pressure and Fnet/100 plotted

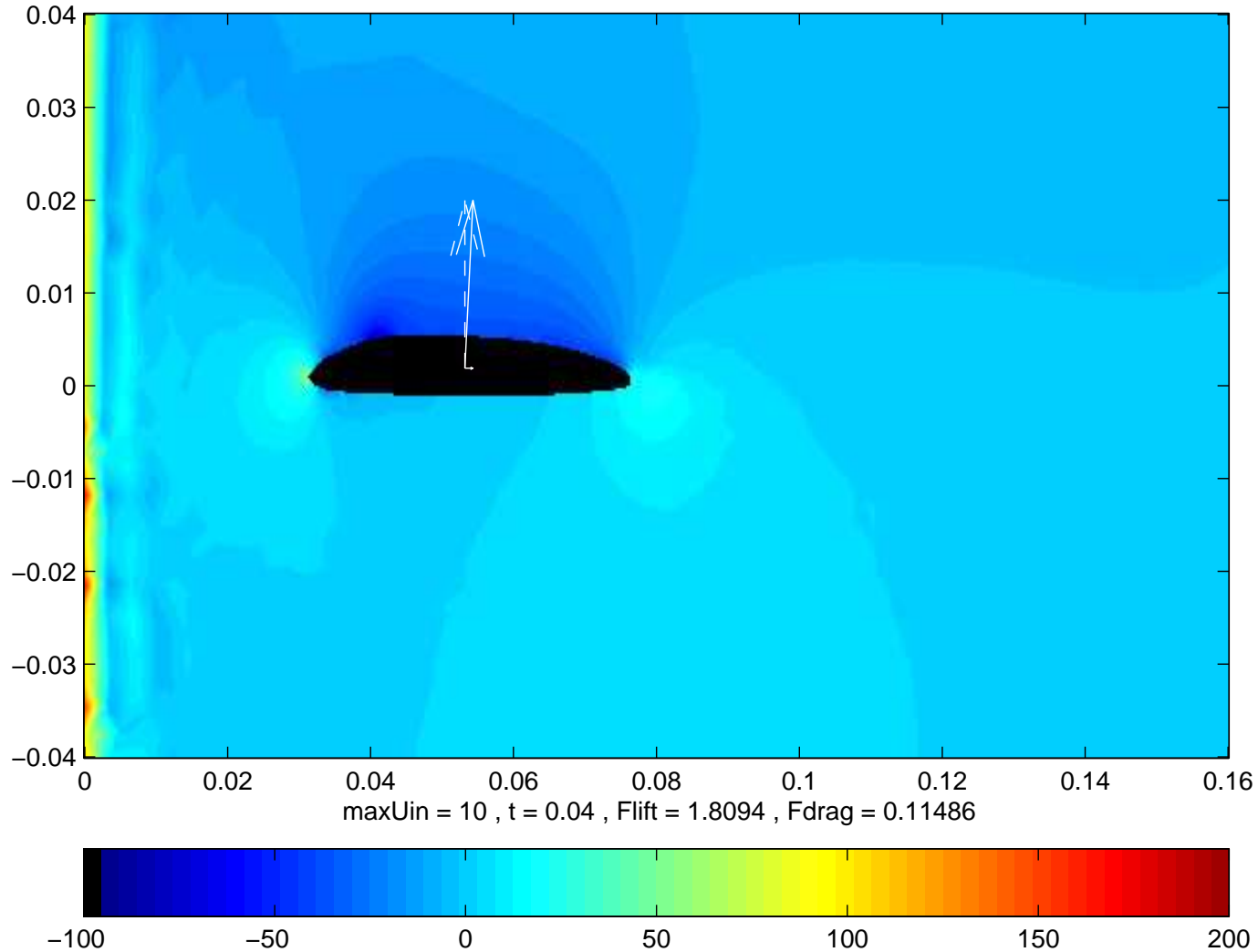

Simulation of $|\mathbf{u}|$ for $\max U_{in} = 14.14$

Speed $|\mathbf{u}|$ from $t = 0$ to $t = .04$, F_{Lift} and F_{Drag}

Re = 38183.7662 , speed and Fnet/100 plotted

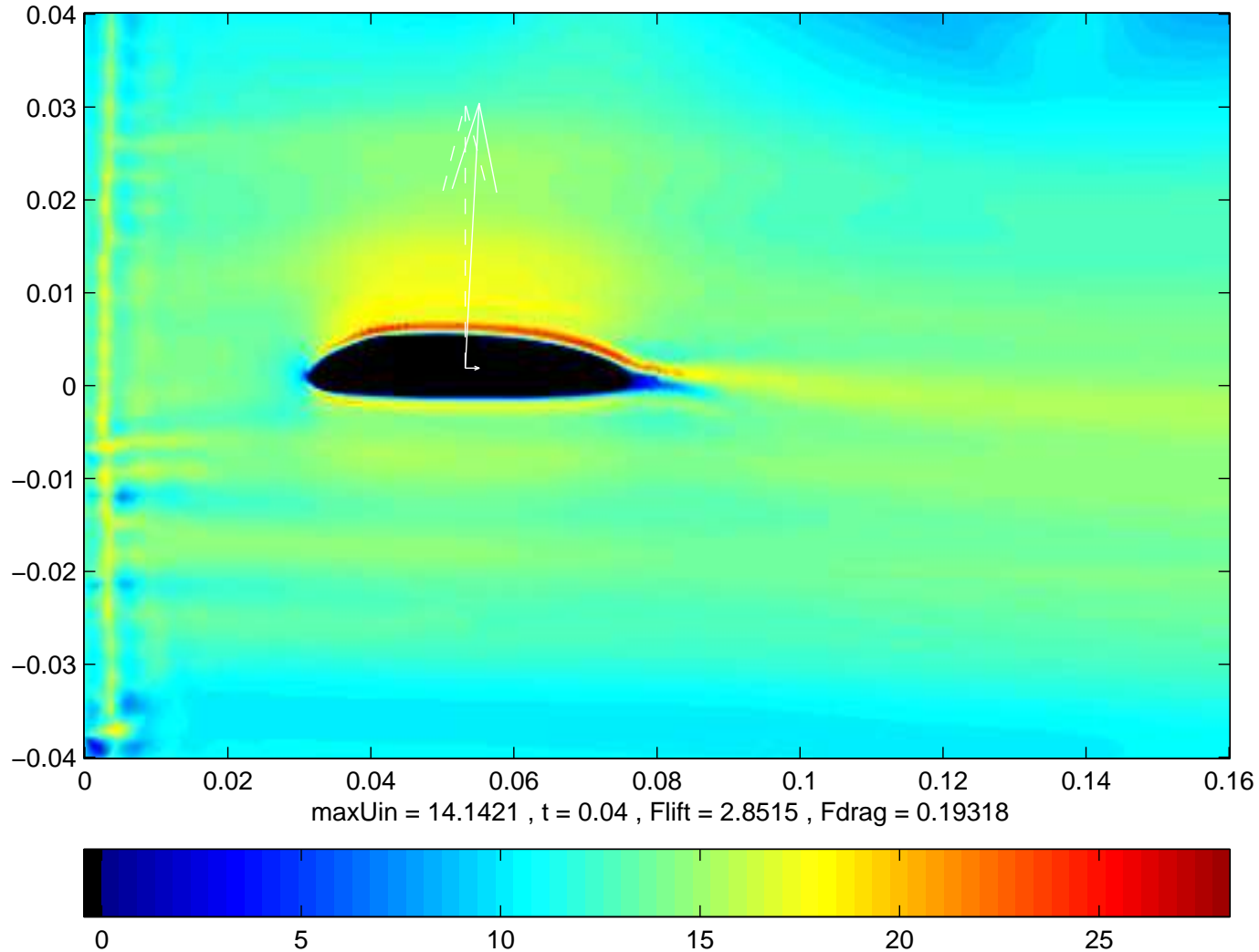

Simulation of P for $\max U_{in} = 14.14$

Pressure P from $t = 0$ to $t = .04$, F_{Lift} and F_{Drag}

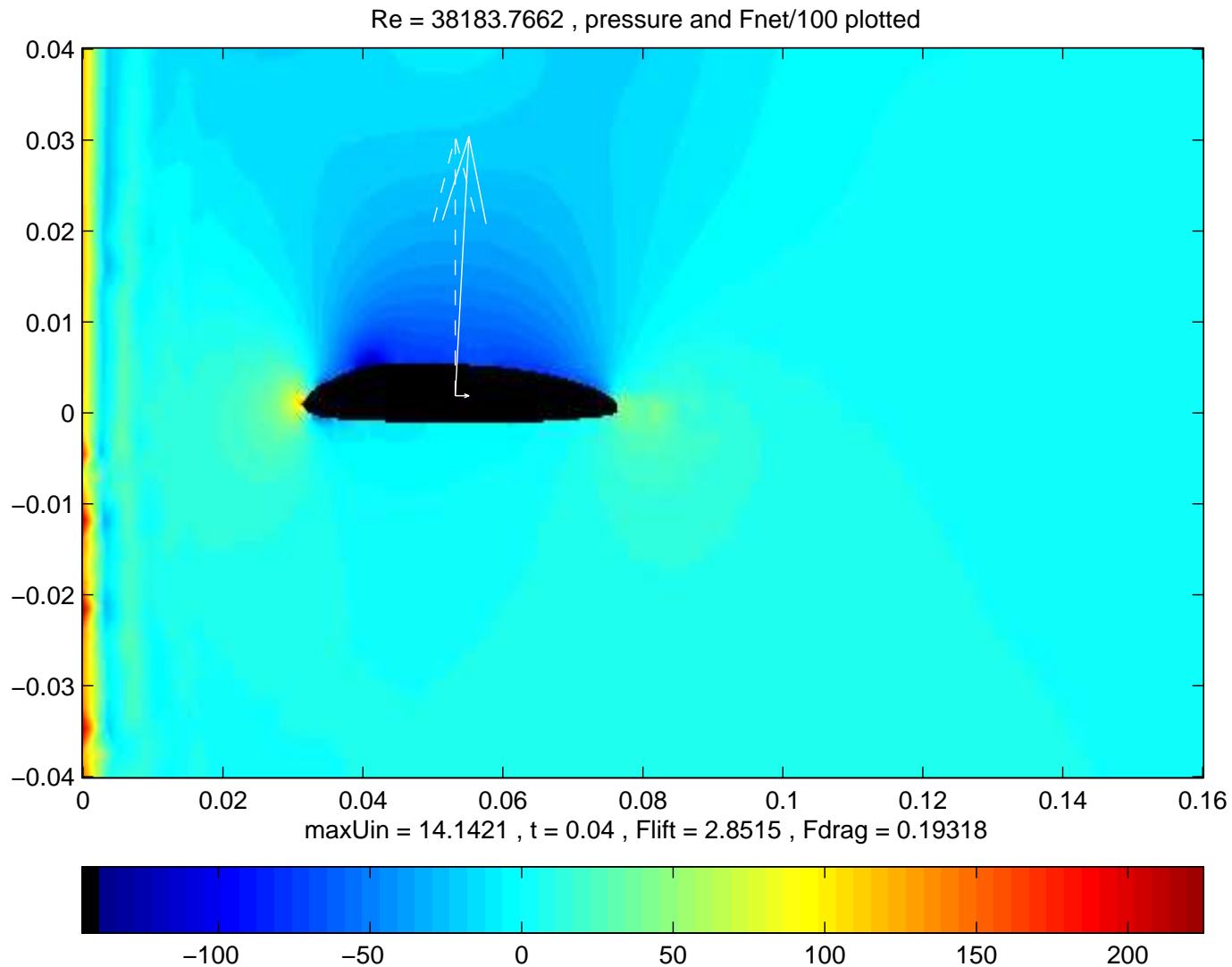

Simulation of $|\mathbf{u}|$ for $\max U_{in} = 5$

Speed $|\mathbf{u}|$ from $t = 0$ to $t = .04$, F_{Lift} and F_{Drag}

Re = 13500 , speed and Fnet/10 plotted

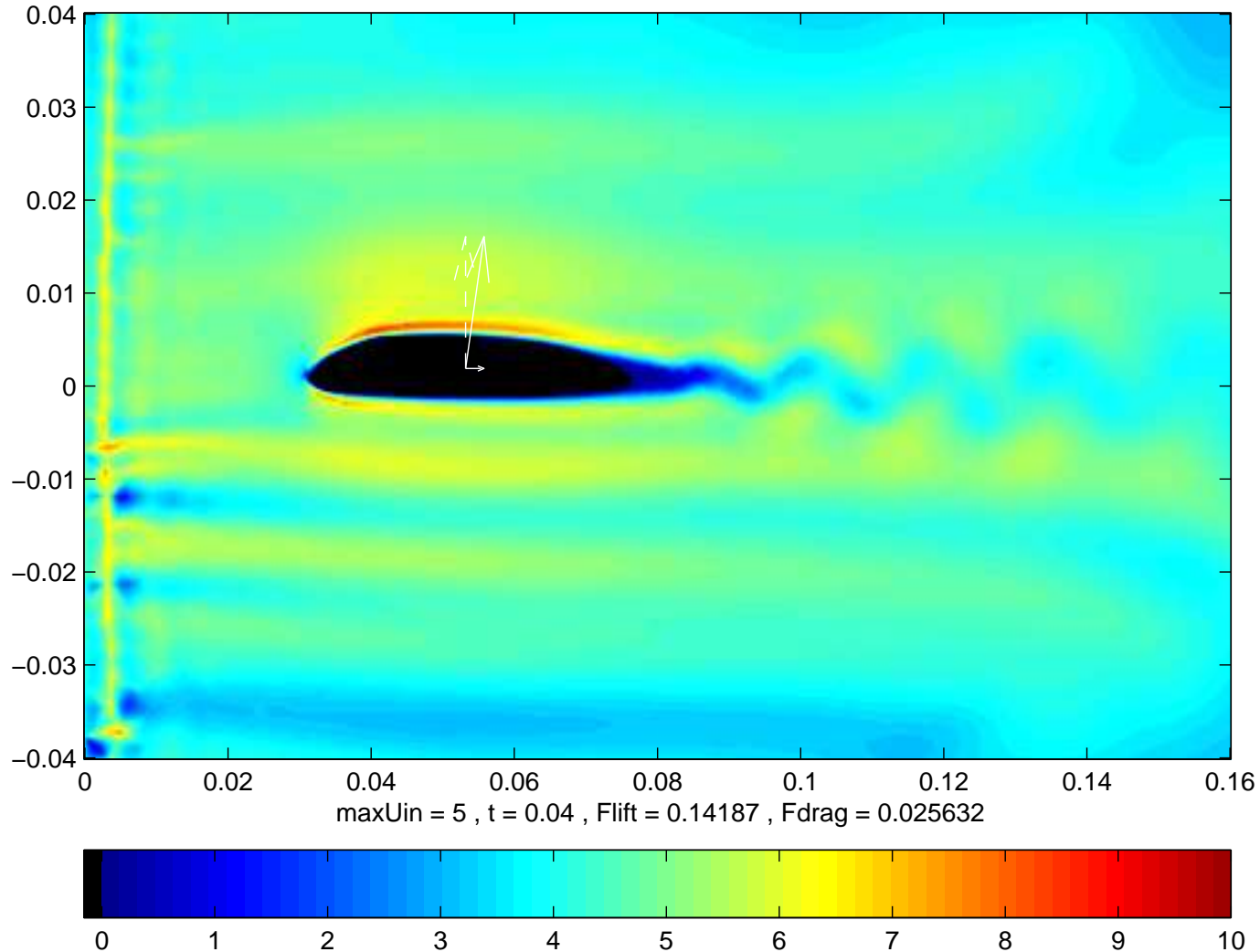

Simulation of P for $\max U_{in} = 5$

Pressure P from $t = 0$ to $t = .04$, F_{Lift} and F_{Drag}

Re = 13500 , pressure and Fnet/10 plotted

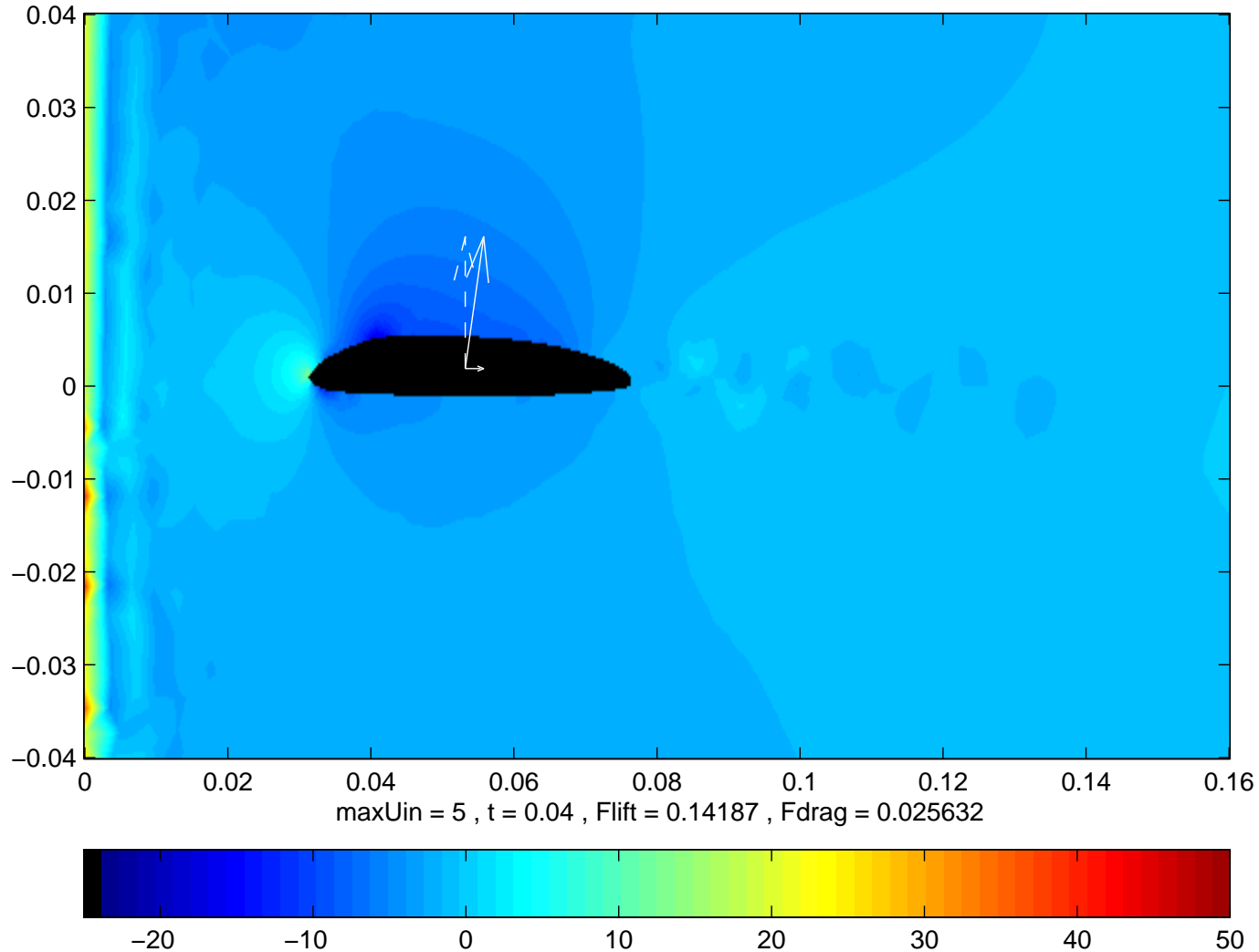

Simulation Comments

- Can see starting vortex shed off trailing edge
- Pressure clearly lower above airfoil
- Velocity also larger near top surface of airfoil
- Thin boundary layer visible
- Earlier boundary layer separation for $Re = 13500$ suggests inviscid approximation not as good for Re in that range or smaller
- Difficult to make simulation stable and accurate for high Reynolds number flows
- Simulated F_{Lift} not exactly following the $F_{Lift} \propto U^2$ model, but we'll call it close enough

A Free-Body Diagram

If we assume the drag force is negligible, then the only forces we consider are the lift force and the force due to gravity.



Assume the boomerang travels in a circular path and let the vertical component of the lift force balance gravity. Then we are left with a net force that is parallel to the ground and can be thought of as a centripetal force.

A Top View of Boomerang Flight

Ω = rate of precession in radians/sec

F_{net} = centripetal force

R = radius of the boomerang's flight path

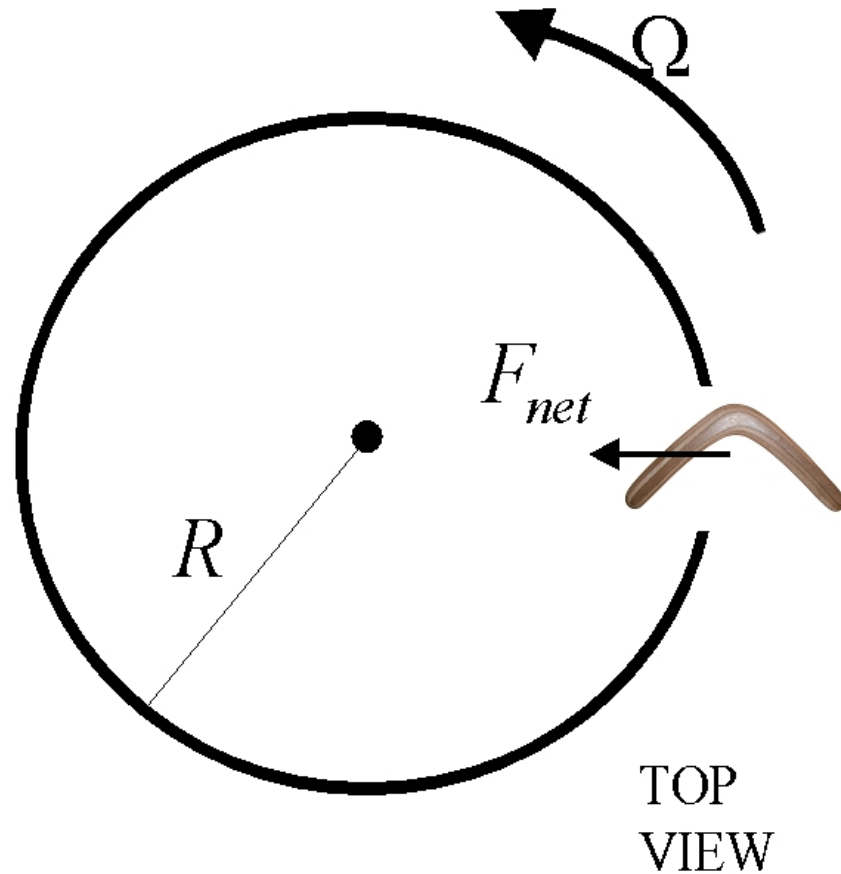

So why does the boomerang turn?

Some Rotational Dynamics

The torque about a point c is defined by

$$\boldsymbol{\tau} = \mathbf{r} \times \mathbf{F}$$

where \mathbf{F} is the force and \mathbf{r} is the vector from c to the point where the force is applied. Torque is a vector and can be thought of in terms of its magnitude and a direction. It's magnitude is defined by

$$|\boldsymbol{\tau}| = |\mathbf{r}||\mathbf{F}| \sin \theta$$

where θ is the angle between the vectors \mathbf{r} and \mathbf{F} .

Right Hand Rule

The direction of the torque is perpendicular to both \mathbf{r} and \mathbf{F} . This direction is determined by the right hand rule:

Point the fingers of the right hand in the direction of \mathbf{r} and curl them in the direction of \mathbf{F} . Then the thumb will point in the direction of the torque τ .

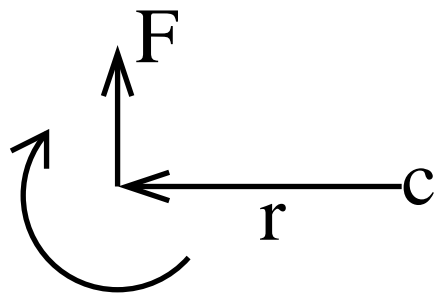

torque points into page

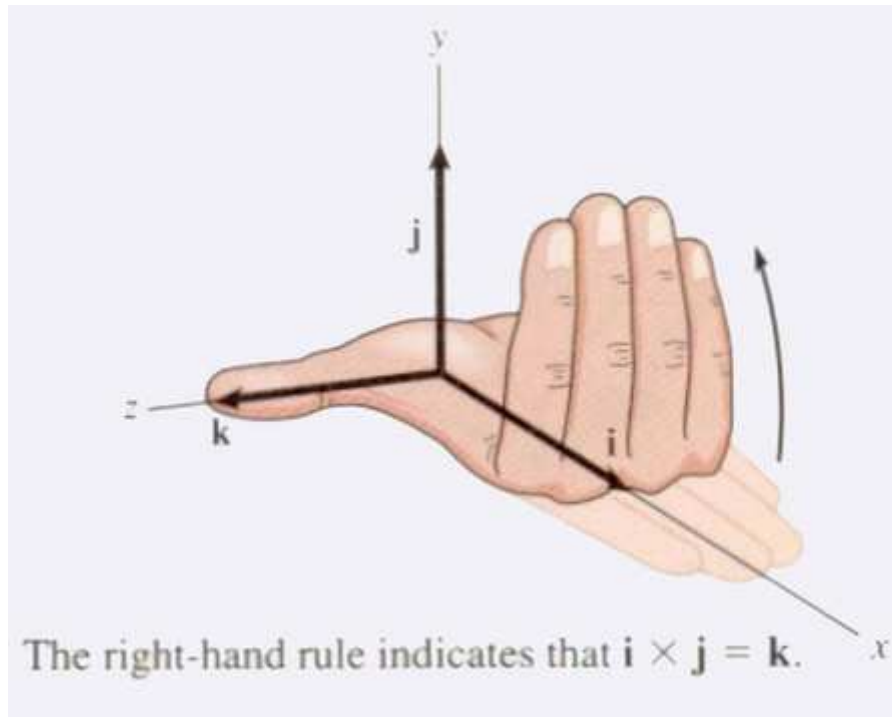

[Bedford and Fowler, *Engineering Mechanics*]

Moment of Inertia

We also have the moment of inertia, I , which describes how difficult it is to rotate a body about some axis. A boomerang, which rotates about its center of mass, will retain its spin better if it has a high moment of inertia.

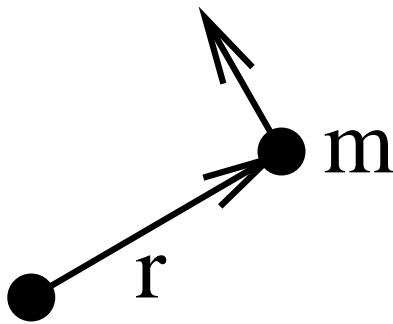

A particle of mass m rotating about an axis at a distance of r , has moment of inertia

$$I = mr^2 .$$

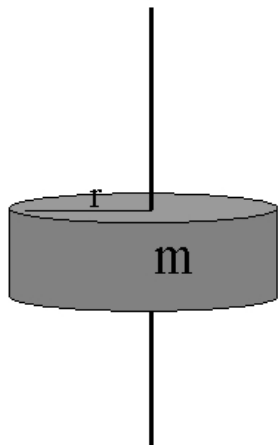

A cylinder of mass m and radius r spinning about its axis of symmetry has the following moment of inertia:

$$I = \frac{1}{2}mr^2$$

Angular Velocity

The angular velocity, ω , describes the rotation of a body about an axis. ω points in the direction of the spin axis and its magnitude is the rate of rotation in radians per second.

For a particle, the relationship between the angular velocity and the linear velocity is given by

$$\mathbf{v} = \boldsymbol{\omega} \times \mathbf{r} .$$

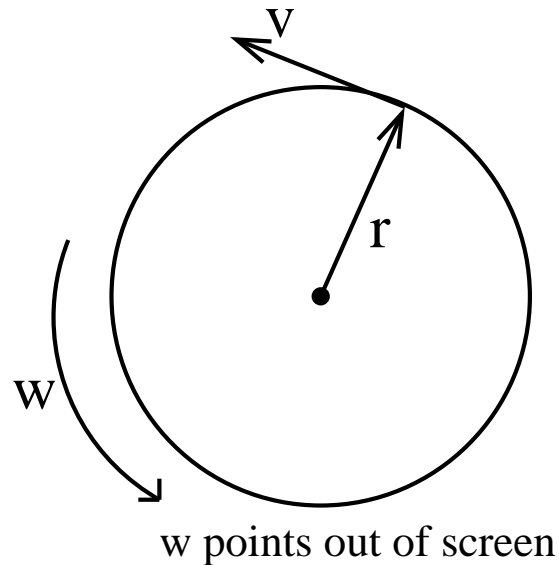

Angular Momentum

The angular momentum, \mathbf{J} , is the rotational analogue to linear momentum. Angular momentum is conserved in the absence of external torque, analogous to how momentum is conserved in the absence of external forces. For a particle, angular momentum is given by

$$\mathbf{J} = \mathbf{r} \times \mathbf{p}$$

where \mathbf{p} is the linear momentum of the particle and \mathbf{r} is its location with respect to some choice of origin.

For an object that is symmetrical about its axis of rotation, the following formula for angular momentum applies:

$$\mathbf{J} = I\omega$$

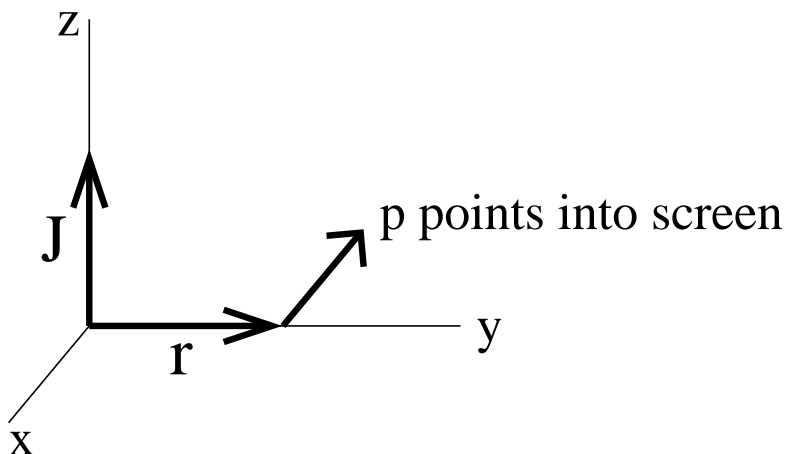

This formula also applies to planar bodies, such as a boomerang, rotating about a perpendicular axis. We take the center of mass to be the origin and let I refer to the moment of inertia about the perpendicular axis through the center of mass.

Principal Axes

For any rigid body, we can always find three perpendicular axes such that when the object is spinning about one of those axis, its angular momentum is in the same direction as its angular velocity.

(This is the spectral theorem applied to the symmetric inertia matrix.)

- For a boomerang in the x - y plane, the z -axis is a principle axis.
- Its moment of inertia I_z about that axis is larger than about any other axis

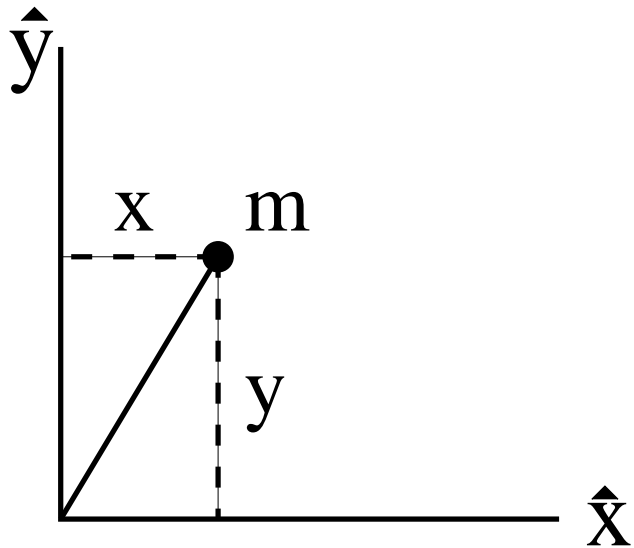

$$I_z = m(x^2 + y^2) = I_y + I_x$$

Relating torque and angular momentum

$$\tau = \frac{d\mathbf{J}}{dt}$$

In words, torque is the rate of change of the angular momentum. This relationship between τ and \mathbf{J} follows from Newton's second Law, $\mathbf{f} = \frac{d\mathbf{p}}{dt}$, which says force is the rate of change of linear momentum.

To simplify, consider a system of masses m_i in a reference frame whose origin coincides with the center of mass and which is not moving relative to the center of mass.

$$\begin{aligned}\mathbf{J} &= \sum_i \mathbf{r}_i \times \mathbf{p}_i \\ \frac{d\mathbf{J}}{dt} &= \sum_i \mathbf{v}_i \times \mathbf{p}_i + \mathbf{r}_i \times \mathbf{f}_i \\ &= \sum_i \mathbf{r}_i \times \mathbf{f}_i \\ &= \tau\end{aligned}$$

Gyroscopic Precession

The equation $\tau = \frac{d\mathbf{J}}{dt}$ says that when a torque is applied to a rotating object such as a boomerang, the angular momentum vector will change so that it points more in the direction of the torque.

DEMO

The rate of precession Ω is related to torque and angular momentum by

$$\tau = \Omega \times \mathbf{J} .$$

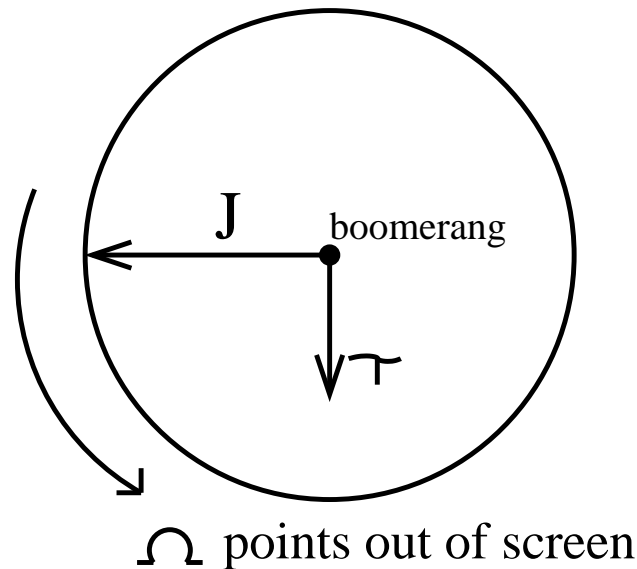

Why is there torque on a boomerang?

The boomerang is moving with linear velocity \mathbf{V} and spinning with angular velocity \mathbf{w} .



This means the top of the boomerang is moving faster than the bottom. Since lift is proportional to the velocity squared, the top part generates more lift than the bottom part. This results in a net torque!

Which way does the boomerang turn?

If we draw the boomerang in the x - y plane traveling in the negative x -direction with the angular momentum vector pointing in the z -direction, we see that the torque points in the positive x -direction.

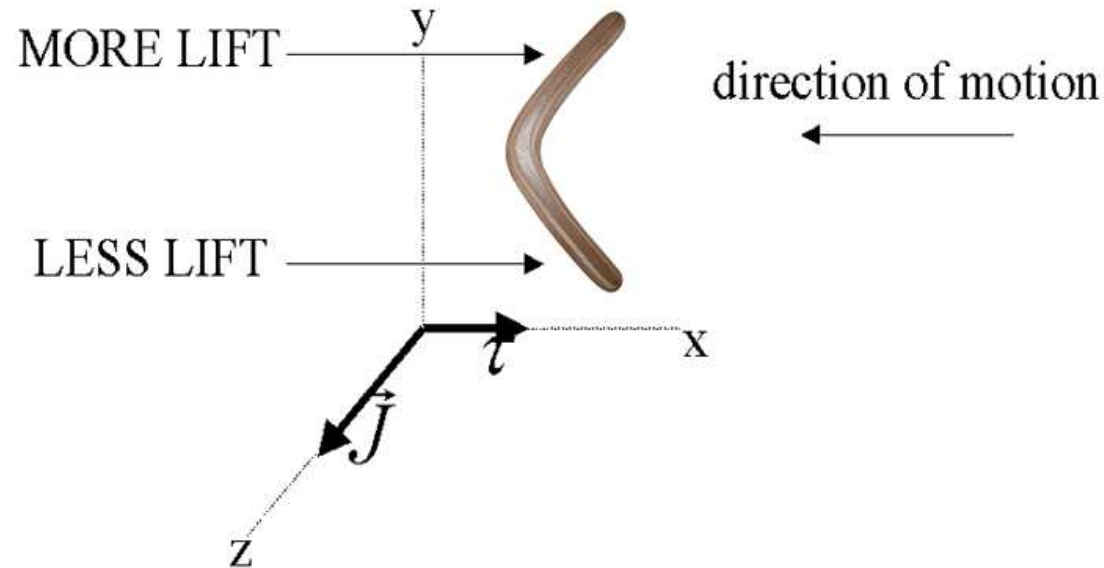

Apply the equation $\tau = \frac{d\mathbf{J}}{dt}$.

Characteristic Radius of Flight

It can be shown ^a that the magnitude of torque on a boomerang is roughly proportional to the product of its linear and angular velocities.

$$\tau \propto v\omega$$

Recalling the relationship between torque and the rate of precession, we have

$$|\tau| = |\mathbf{\Omega} \times I\omega| = cv\omega$$

for some constant c .

Canceling ω implies $\Omega = \tilde{c}v$ for some constant \tilde{c} . And since we also know $\Omega = \frac{v}{R}$, where R is the radius of the boomerang's flight, we see we can solve for R and that is it independent of ω and v .

$$R = \frac{1}{\tilde{c}}$$

Note: If we can compute τ we can compute R .

^a[Felix Hess, *The Aerodynamics of Boomerangs*]

Compute torque for Roomerang

The Plan:



Use the lift equation to compute the lift force and torque produced by a four-bladed windmill-shaped boomerang. Then estimate the characteristic radius of the boomerang.

Assumptions:

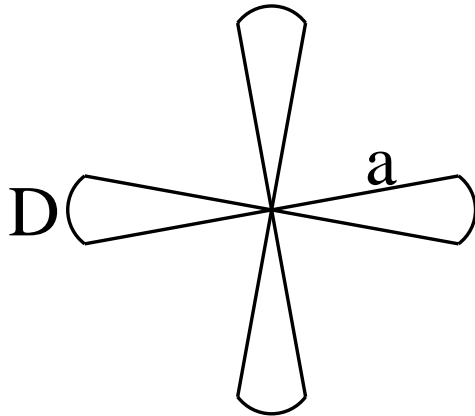

- Symmetrical windmill-shaped boomerang
- Constant layover angle ϕ
- Boomerang travels in level circle
- Lift equation $F_{Lift} = \frac{1}{2}\rho U^2 C_L A$ applies
- Lift coefficient C_L constant along wings of boomerang

Making Use of Symmetry

Here we are concerned with the torque about the x -axis, which is the torque that causes the main precession of the boomerang.

We will simultaneously consider the contribution to torque about the x -axis from each of the 4 arms.

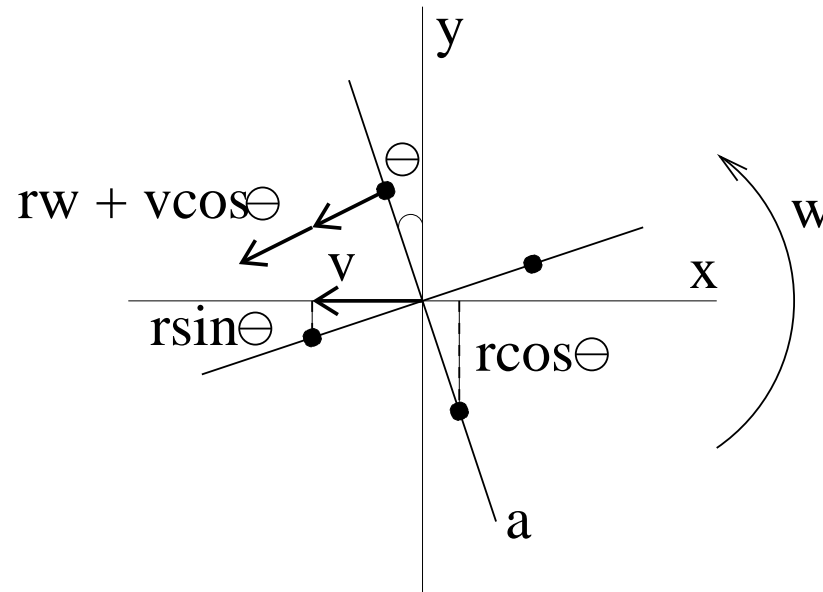

Adding up the torque

Let $j = 1, 2, 3, 4$ index the four arms of the boomerang.

$$\begin{aligned}\sum_j \tau_j(r, \theta) dA &= \sum_j \frac{1}{2} \rho C_L v_j(r, \theta)^2 y_j dA \\ &= \frac{1}{2} \rho C_L dA [r \cos \theta (v \cos \theta + r\omega)^2 + r \sin \theta (v \sin \theta + r\omega)^2 \\ &\quad - r \sin \theta (v \sin \theta - r\omega)^2 - r \cos \theta (v \cos \theta - r\omega)^2] \\ &= 2\rho C_L r^2 \omega v dA\end{aligned}$$

By symmetry, τ does not depend on θ .

Now integrating in polar coordinates gives the total torque

$$\begin{aligned}\tau &= 2D\rho C_L \omega v \int_0^a r^3 dr \\ &= \frac{D}{2} \rho C_L a^4 \omega v\end{aligned}$$

Thus τ is proportional to ωv .

Solving for R

Recall that $\boldsymbol{\Omega} = \frac{\mathbf{v}}{R}$ and $\boldsymbol{\tau} = \boldsymbol{\Omega} \times \mathbf{J}$.

Since $\mathbf{J} = I\boldsymbol{\omega}$ and the layover angle is assumed to be ϕ , we get

$$\boldsymbol{\Omega} = \frac{\boldsymbol{\tau}}{I\boldsymbol{\omega} \cos \phi} .$$

Next plug in our formula for torque, $\tau = \frac{D}{2}\rho C_L a^4 \omega v$.

$$\frac{v}{R} = \frac{D\rho C_L a^4 \omega v}{2I\omega \cos(\phi)} \Rightarrow R = \frac{2I \cos \phi}{D\rho C_L a^4}$$

We can get a more specific estimate for the windmill boomerang by substituting $I = \frac{1}{2}ma^2$, $D = \frac{\pi}{8}$ and $\cos \phi = \frac{\sqrt{3}}{2}$. Then

$$R = \frac{4\sqrt{3}m}{\pi a^2 \rho C_L} .$$

Implications of the equation for R

$$R = \frac{2I \cos \phi}{D\rho C_L a^4}$$

- Under our assumptions, R is independent of v and w . Thus the range of a boomerang doesn't depend on how it is thrown. R is instead a property of the boomerang itself.
- A larger moment of inertia implies a bigger radius.
- Lower air density results in a larger radius.
- More wing area gives the boomerang a smaller flight radius.
- A larger lift coefficient also causes reduced range.

An Interesting Inverse Problem

The lift coefficient is extremely difficult to explicitly compute. Fortunately, our equation for R gives us an easy way to determine C_L experimentally.

1. Solve equation for C_L .

$$C_L = \frac{4\sqrt{3}m}{\pi a^2 \rho R}$$

2. Measure air density.

$$\rho \approx 1.2 \frac{kg}{m^3}$$

3. Find mass of Roomerang.

$$m \approx .005kg$$

4. Estimate wing angle D and wing radius a .

$$D \approx \frac{\pi}{8} \text{ and } a \approx .14m$$

5. Throw boomerang and measure R .

$$R \approx 1m$$

6. Plug everything in.

$$\boxed{C_L \approx .45}$$

This gives us a rough approximation for the lift coefficient of the Roomerang.

Extension to Classical Boomerang Shape

Without special symmetry, the lift force and torque produced by the boomerang depend on the angle of rotation. Felix Hess's lift diagram below illustrates the non-symmetric lift force for the lifting arm as it sweeps out a circle. (The darker color corresponds to more lift.)

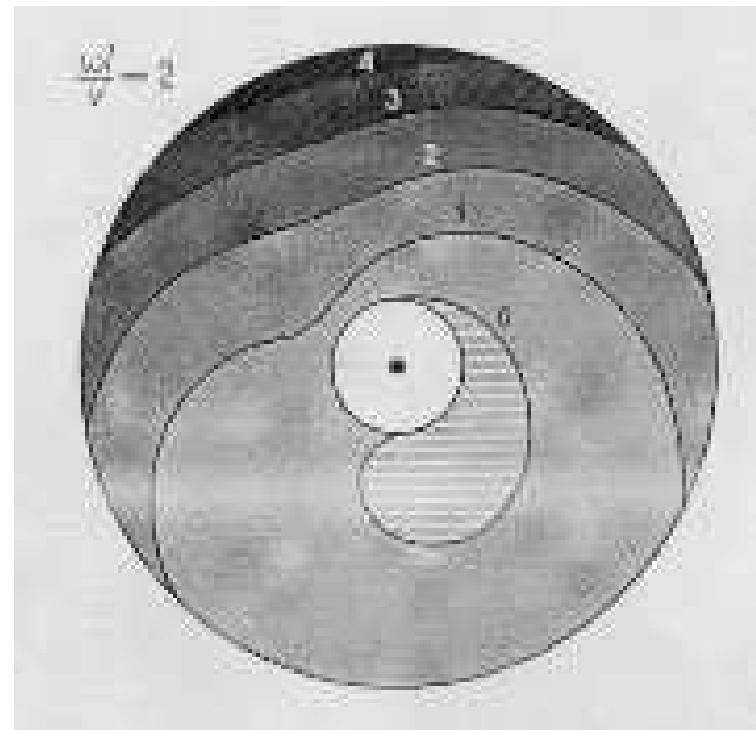
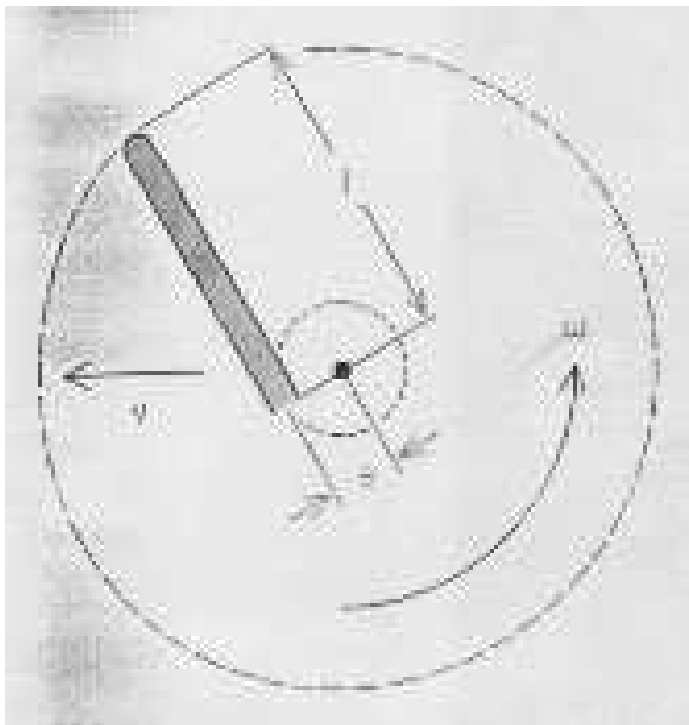

[Felix Hess, *The Aerodynamics of Boomerangs*]

The situation can be simplified by using time averages of lift and torque to approximate the previous calculations.

What Makes a Boomerang Lay Over?

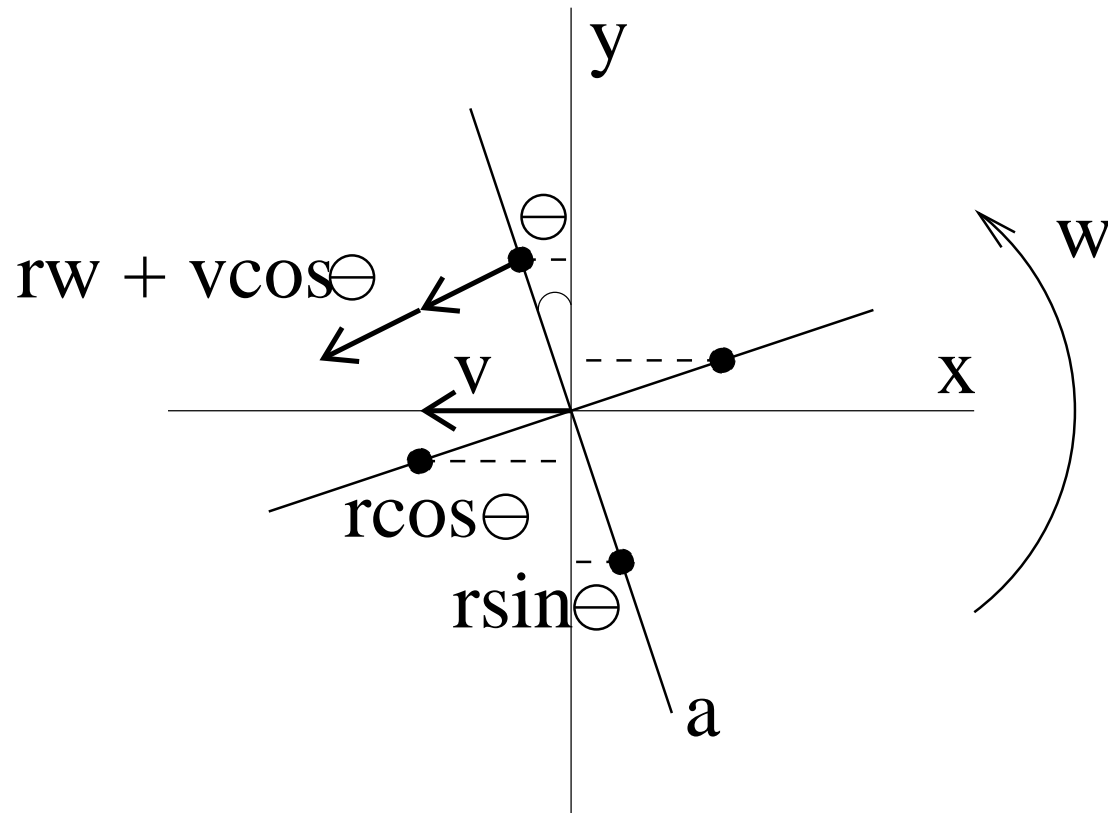

A torque about the y -axis causes the boomerang to precess about the x -axis. Thus a positive torque in the y -direction will cause the boomerang to lay over.

The Drafting Effect

The leading arms of boomerangs disturb the air so that the trailing arms generate less lift than they normally would. There is a resulting torque in the positive y -direction. The drafting effect is the most significant source of this torque because it affects even radially symmetric boomerangs.

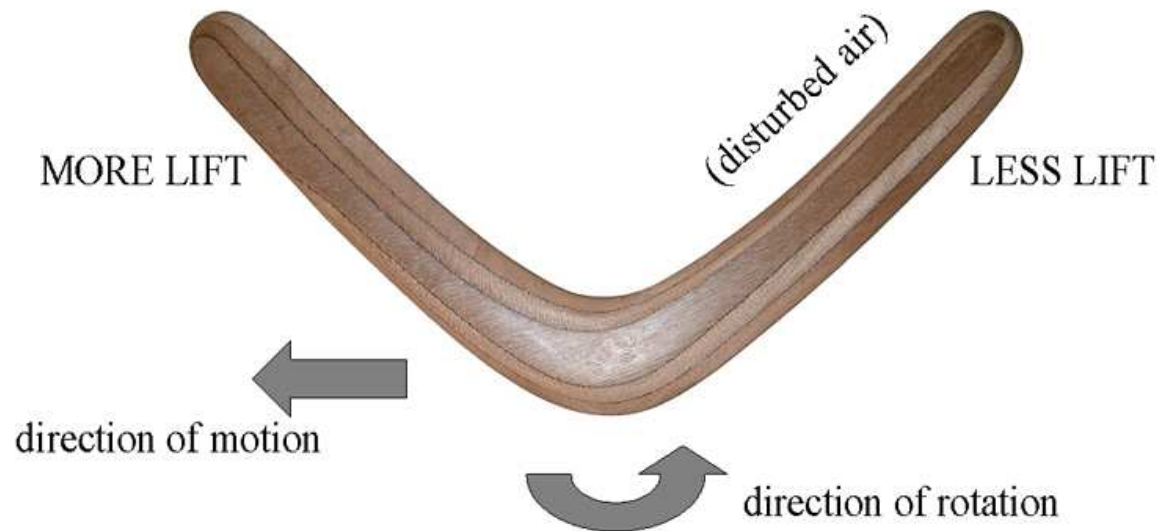

Adjusted Torque Computation

Without this drafting effect, our Roomerang generates no torque in the y -direction. Analogous to our earlier computation

$$\begin{aligned}\sum_j \tau_j(r, \theta) dA &= - \sum_j \frac{1}{2} \rho C_L v_j(r, \theta)^2 x_j dA \\ &= \frac{1}{2} \rho C_L dA [r \sin \theta (v \cos \theta + r\omega)^2 - r \cos \theta (v \sin \theta + r\omega)^2 \\ &\quad + r \cos \theta (v \sin \theta - r\omega)^2 - r \sin \theta (v \cos \theta - r\omega)^2] \\ &= 0.\end{aligned}$$

With less lift on the trailing arms, the two red terms actually have less effect. This results in a positive torque in the y -direction.

Eccentricity Torque

Eccentricity torque is only an issue with non-radially symmetric boomerangs, and is caused when there is unequal lift on arms with nonzero eccentricity. The eccentricity refers to the perpendicular distance between an arm and the center of mass.

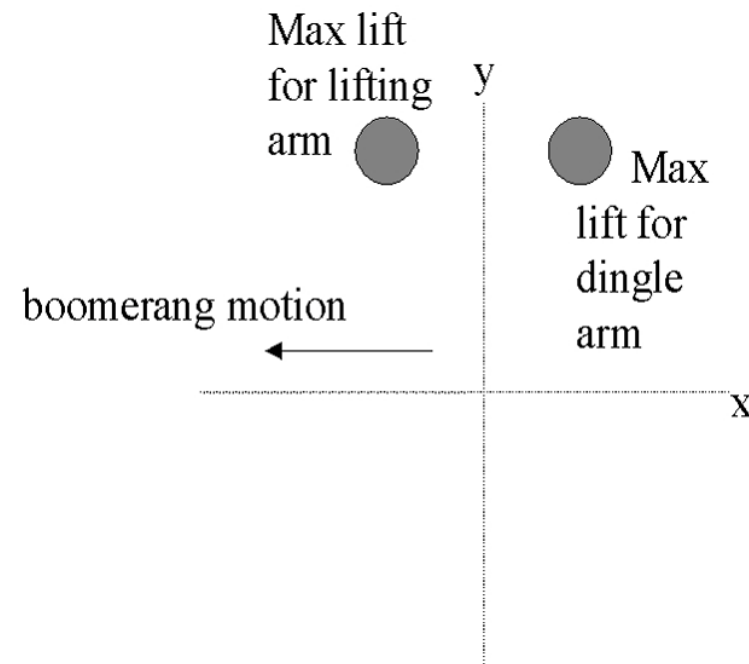
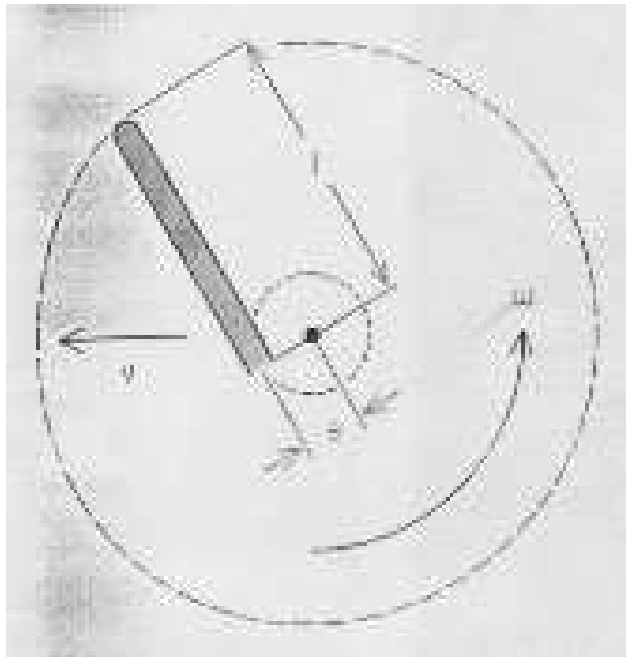

If the lifting arm generates more lift than the dingle arm, the resulting torque in the y -direction causes the boomerang to lay over faster.

Boomerang Construction and Tuning

Tools and Supplies:

Warp-resistant plywood, coping saw (or band saw!), drill sander, wood file, knife, sandpaper, and patience.

Woodworking
Irreversibility:

Err on the side of removing less wood for the first test flight, because it's easy to take wood off but challenging to put it back on.

Adjusting Weight
Distribution:

- Adding mass to the ends of arms increases the moment of inertia resulting in longer range and better wind resistance.
- Adding mass to center improves wind resistance and stability.
- A lot of very fine tuning can be accomplished by adding small weights to various parts of a boomerang.

Adjusting Lift Properties

- We can alter the shape of the bevels and airfoils to increase or decrease the lift generated.
- More lift on the lifting arm yields a faster layover.
- More lift on the dingle arm results in less layover and a flatter, more circular flight.
- Larger bevels increase lift and torque, causing the boomerang to make a tighter turn.
- Too much lift can cause too tight of an orbit.
- Streamlining is important and can sometimes save a boomerang that prematurely runs out of spin.
- Conversely, a rougher surface isn't necessarily bad and can occasionally improve flight characteristics.

Warping Effects

A warped boomerang is not necessarily a broken boomerang.

- A warped boomerang that is concave up will have reduced range, but a concave down boomerang might not fly at all.
- The arms of a boomerang can be twisted to give them a positive or negative angle of attack.
- More fine tuning can also be accomplished by turning the tips of the arms up or down.
- A warping caution: I've found that intentionally warping a boomerang is often only a temporary change, and the results can be inconsistent.



General Throwing Tips

Two Throwing Grips:

Cradle grip

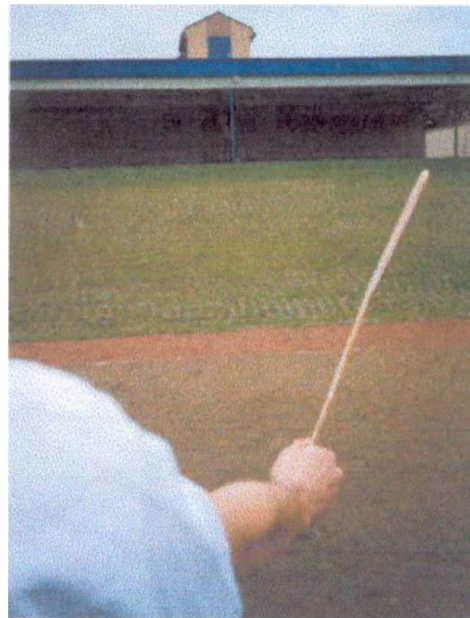

Pinch grip



[Aboriginal Steve's boomerang page]

The Throwing Angle

Robot Pinch Grip



Throwing and Troubleshooting

- The contoured side of the boomerang needs to be facing you.
- Throw boomerang directly ahead or slightly upward with moderate power and spin.
- Use a layover angle of about 30 degrees or less. **Do not throw sidearm.**
- In windy conditions, throw about 45 degrees to the right of the oncoming wind (to the left for left-handers using a left-handed boomerang).

Troubleshooting the Throw

Lands too far in front	Aim lower or throw harder
Lands too far behind	Aim higher or throw softer
Lands to the left	If wind, aim more to the right
Lands to the right	If wind, aim more into it
Flies too high and lands in front	Use less layover
Hits ground too soon	Aim higher or throw harder
Just doesn't quite make it back	Try more layover, power and/or spin

A Word on Catching and Safety

A Good Catch

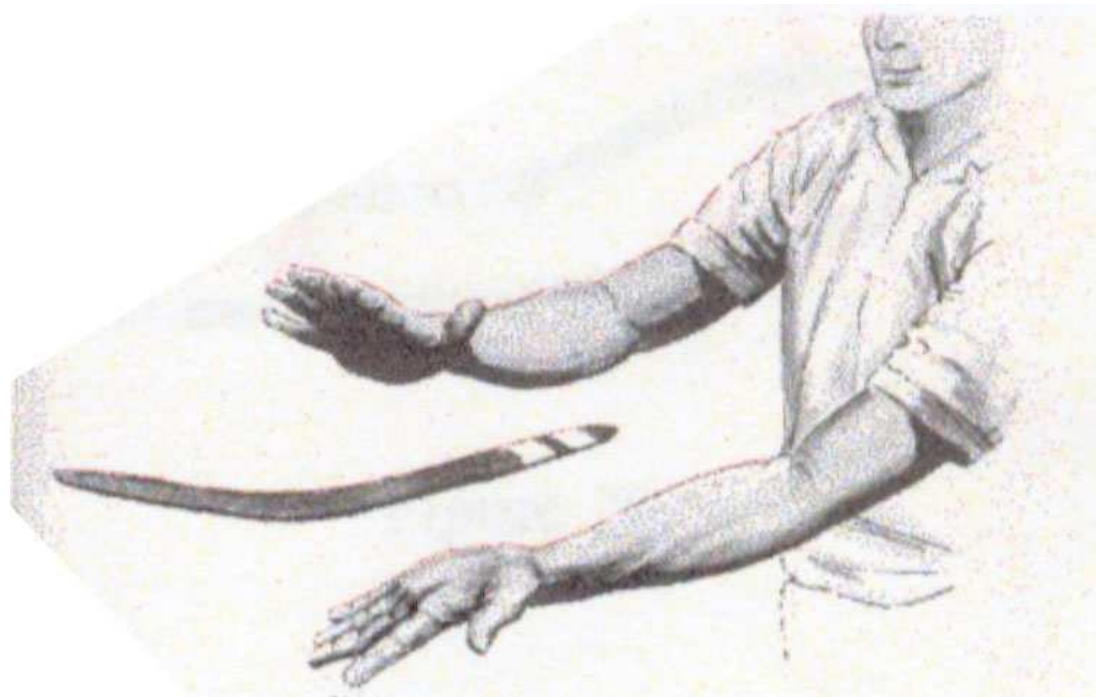

[Hawes, *All About Boomerangs*]

Throw in a large open area devoid of potential boomerang victims (people, windows, anything expensive) as well as boomerang predators (power lines, trees, pit bulls). Only one boomerang at a time should be in the air so that no one's attention is dangerously divided.

DO NOT GET DISTRACTED!



Always keep your eyes on a thrown boomerang. It has a tendency to come back. Either catch it, dodge it or protect yourself!

References

- Acheson, D.J. *Elementary Fluid Dynamics*, 2005.
- *Boomerang Passion* [<http://www.boomerangpassion.com/english.php>]
- *European Boomerang Links*
[<http://www.flight-toys.com/boomerang/europe.htm>]
- Hawes, Lorin Lindley and Mauro, John, *All About Boomerangs*, 1987.
- Hess, Felix, *The Aerodynamics of Boomerangs*, 1968.
- Hunt, Hugh, *Unspinning the Boomerang*
- Landau and Lifshitz, *Mechanics*
- Majda, Andrew J. and Bertozzi, Andrea L. *Vorticity and Incompressible Flow*, 2002.
- Pakalnis, Saulius, *Aerodynamics of Boomerang*,
[http://researchsupporttechnologies.com/boomerang_site/boomerang1.htm]
- Persson, Per-Olof, and Strang, Gilbert.
[<http://www-math.mit.edu/persson/mesh/>]
- Reid, Robert, *The Physics of Boomerangs*, 1984.